

Switched Current Power Converter Schematic Diagram

Edward Herbert
July 18, 2005

Following are three pages of schematic diagrams showing the components of a representative switched current power converter that is providing power to a processor. To a large extent, the cost trade-off against a multi-phase buck converter VRM is the elimination of the bulk capacitors versus extra silicon. Not only do the bulk capacitors have a cost, they occupy a lot of motherboard area, and saving real estate has a value. Other circuits are greatly simplified, which have cost benefits above and beyond a parts count alone.

Top Level Schematic:

The first page of the schematic shows the top level schematic with blocks for control and power. It is a representative circuit diagram using the capacitors found in VRM guidelines, Intel document number 306760-001, "Voltage Regulator Module (VRM) and Enterprise Voltage Regulator-Down (EVRD) 10.2", March 2005. The bulk capacitors are left out, as they are not needed.

The feedback network is entirely passive and implements a total charge measurement with supplemental output voltage remote sense. None of the components are critical. Changing any value by 50 percent had little impact on the performance in a SPICE simulation. While the component are shown with the values used in the SPICE simulation, they may vary in value and arrangement from application to application.

The power input V_s is shown as +12 volts, but other power sources can be used.

Control ICs:

The second page of the schematic shows two alternative control integrated circuits. The first, A, is a basic control, and is the one used in a SPICE simulation. The output voltage (or the total charge sense, TQ) is taken to the comparators, and the outputs of the comparators S1, S2, etc., are the logic output to the power circuits. The resistor ladder network is shown simplified in this diagram. While the circuit will function just as shown, it is preferred to add hysteresis. A concern in designing a resistor network for manufacture is that the resistors should be neither too large (in value) nor too small, and adding hysteresis in the conventional manner (a resistor from the output to the non-inverting input) requires a very large value resistor. An alternative design uses about 40 resistors, none less than 10 Ω nor greater than 2000 Ω . If whole ladder hysteresis is used, one small capacitor may be needed, external to the IC. The absolute value of the resistors is not critical as long as the relative values are precise. This is compatible with high volume production using laser trimming. A precision voltage reference sets the output voltage.

The second integrated circuit, B, is shown with several possible variations and enhancements. The voltage reference may be deleted so that the output voltage can be varied by external command. An error amplifier may be added, to provide a constant voltage output or for a remote sense. A tri-state driver array may be added to sequence the switches for power sharing, and the tri-state drivers may have a sequencing circuit, such as a binary counter with a 1 of n decoder.

Power Circuits:

The third page of the schematic shows alternative power circuits. In both cases, the control inputs S1, S2, etc. are the outputs of the control integrated circuit described above. They control whether an increment of current is switched to the output, designated I_c . Regardless of the configuration of power source used, these control signals are invariant, so that different input power sources and different output control circuits can be mixed and matched at this interface with no other changes.

The basic circuit, A, has a quantity n of constant currents as its power source, one constant current at each of the inputs I_1, I_2 , etc. The nature of the current sources is not important as long as the currents are reasonably stable dc currents.. For prototyping, laboratory bench power supplies in constant current mode work well. MOSFETs and their drivers switch the current to the output, designated I_c , as required. The MOSFETs and their drivers preferably are very fast, but the design is simplified considerably because the current is always the same.

For early adoption of the switched current power converter, the circuit B likely will be preferred, as it uses the existing 12 volt input, and the circuit can borrow from the existing multiphase buck converter technology, with important simplifications described below.

In each of the inductors, a nominally dc current is established and maintained. The output of the inductors is switched by MOSFETs, exactly as in the basic power circuit As described above.

The accuracy of the current sources need not be high. Ten percent is probably acceptable, though a detailed analysis should be made for each application. The dynamic response of the multi-phase buck current regulator has no impact on the final output, so its frequency can be low to reduce switching losses and increase efficiency. Because the current is always the same, the MOSFETs and their drivers can be optimized for that current. If the number of phases is less than the ratio of V_i to V_o , a single current sense is used, and it will sense a low current, equal to the maximum output current divided by the number of phases n ..

The number of phases is somewhat arbitrary, but it is not a big driver in the cost, and more phases may be more economical if it allows a higher degree of integration. The total current being switched largely determines the total area of silicon needed for the power switches, and dividing it into fewer or more channels largely affects the logic only. A larger quantity of smaller inductors (physically – they would have a higher value) probably is not a cost driver if there are offsetting advantages, and possible discrete inductors could be replaced with multiple inductor dip like integrated packages.

Note was made on the schematic of the transformer version of the power circuits though they are not shown. The transformer uses a coaxial transformer, which is very simple, so a trade off of transformer sections versus inductors is fairly close. The transformer version has better efficiency, particularly at light loads. It also provides isolation, so the up-stream power source can be simplified. Direct input from unisolated 48 volts is easily accommodated, as is a direct input from an unisolated PFC front end. In each case, a single output buck derived constant current source is used. With hysteretic control, this is a very simple circuit compared to the usual isolated 12 volt voltage source, one that would be much less expensive and more efficient.

Switched Current Power Converter

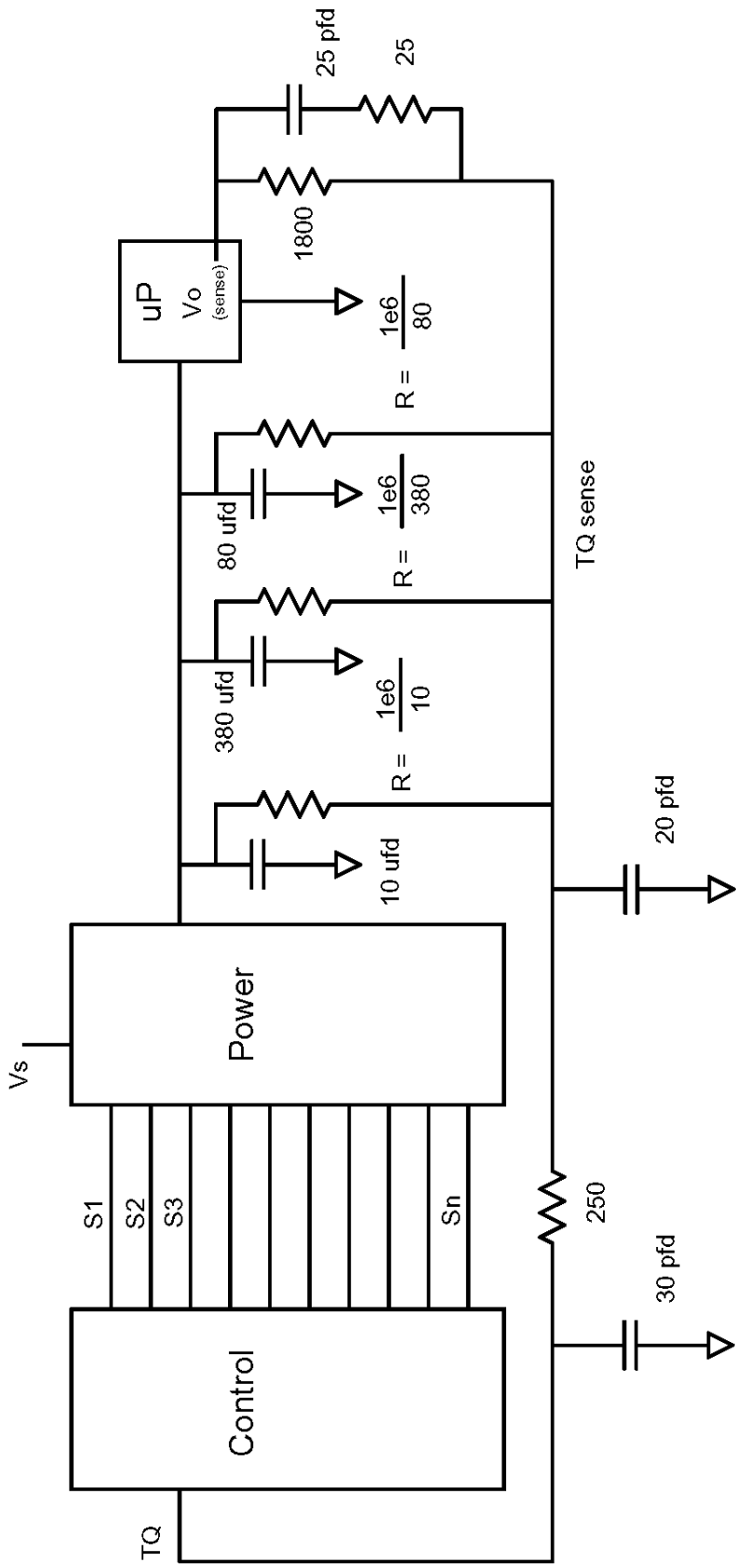

Control ICs

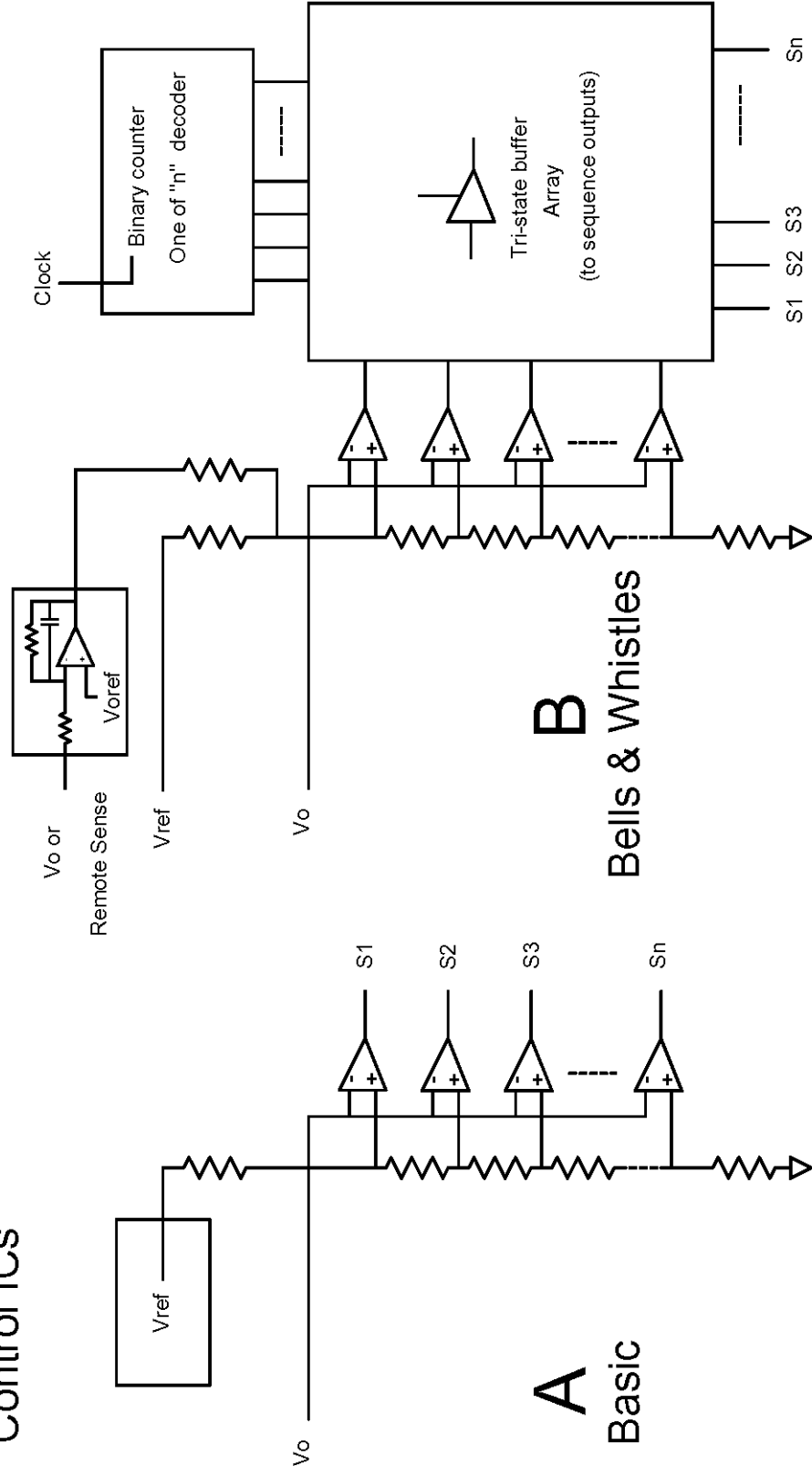

A

Basic

B

Bells & Whistles

Power

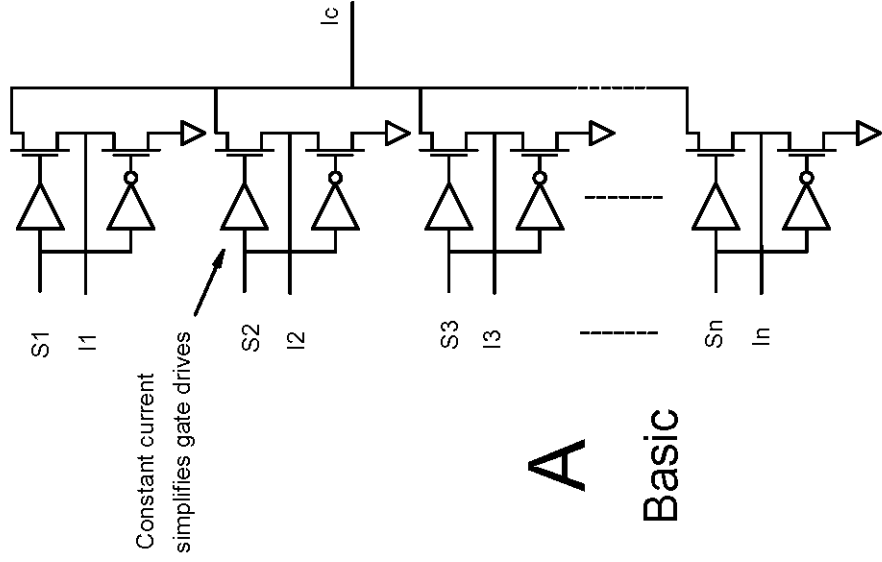

A

Basic

C Transformer version (Not shown)

+12

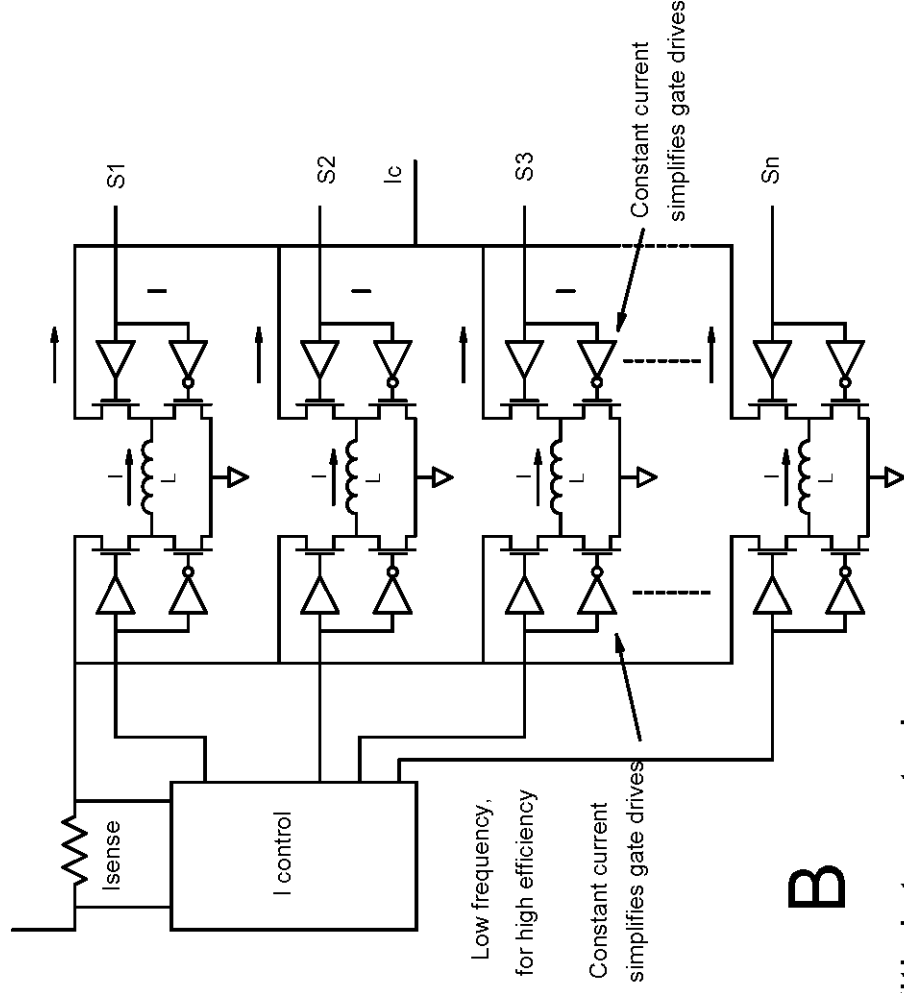

B

With integrated Current Sources